

**The 19th International Conference on
“Technical and Physical Problems of Engineering”
ICTPE-2023
31 October 2023
*International Organization of IOTPE***



MINIMIZATION OF MERCURY DOSING INTO A GAS-DISCHARGE LAMP

S.A. Baghirov

Azerbaijan Technical University, Baku, Azerbaijan

Content

- **INTRODUCTION**
- **FEATURES OF THE PROCESSES OF EVAPORATION AND CONDENSATION OF MERCURY IN LL**
- **RESEARCH RESULTS**
- **CONCLUSION**

The 19th International Conference on “Technical and Physical Problems of Engineering” (ICTPE-2023)

INTRODUCTION

Currently, along with the energy efficiency and quality of illumination of light sources, special attention is also paid to their environmental problems. Along with the development of modern environmentally friendly LED lamps, the production and application of compact and tubular luminescent lamps (LL) occupies one of the leading places in the lighting industry. LL are used for lighting industrial, public buildings, offices, educational institutions, in technological processes, in medicine, etc. Compact LLs are widely used in residential lighting. The increase in the production and application of LLs constantly increases the requirements for the technology of manufacturing these lamps. In the production of LL, one of the technological operations is the dosing of mercury into the lamp.

The 19th International Conference on “Technical and Physical Problems of Engineering” (ICTPE-2023)

In LL, performance is a major factor, but environmental concerns also play an important role. First of all, these problems relate to the dosing of mercury into the lamp. The amount of mercury in the lamp, necessary for its normal functioning throughout the entire service life, is about 5-10 mg. However, the lack of reliable means and perfect methods for dosing mercury leads to an increased content of it in LL (60÷120 mg).

European legislation on requirements for sustainable design and construction of lamps has adopted a number of regulations aimed at reducing the mercury content in discharge lamps. The regulations formulate requirements to increase the luminous efficiency of LLs and reduce the mercury content in them, based on the gradual abandonment of lamps with halophosphate phosphors.

The 19th International Conference on “Technical and Physical Problems of Engineering” (ICTPE-2023)

An analysis of technical regulations based on the directives of the European Parliament regarding the requirements to reduce the mercury content in LL shows that the manufacturer must provide consumers with the following information: the amount of mercury in the lamp; how to dispose of the lamp after its failure; how to deal with lamp waste if it is accidentally destroyed.

The 19th International Conference on “Technical and Physical Problems of Engineering” (ICTPE-2023)

Conducted in scientific and technical developments and projects, the issue of accurate dosing and mercury content in LL is also very acute. The limit values for the amount of mercury by types of LL are shown in Table 1.

Table 1. Amount of mercury in LL

Type of fluorescent lamp	Characteristics of lamps	The amount of mercury in the lamp, mg
Linear fluorescent lamp T12 with a diameter of 38 mm	Poor energy efficiency and high mercury content	5-90
Linear fluorescent lamp T8 with a diameter of 26 mm	The most commonly used fluorescent lamp	<10
Linear fluorescent lamp T5 with a diameter of 16 mm	Alternative to T8 fluorescent lamps	<5
Compact fluorescent lamp	Alternative to incandescent lamps	<5

The 19th International Conference on “Technical and Physical Problems of Engineering” (ICTPE-2023)

For many decades, the most widely used devices dosing mercury in the liquid state. With liquid dosing, it is necessary to take into account the large length of the mercury transportation path from the dispenser to the exhaust tube. When transporting mercury into the lamp, a drop of mercury can be deposited on the walls of the dispenser, which leads to an underestimation of the amount of mercury in the lamp, and if a drop of mercury is trapped on the walls, it can lead to an overestimation of its amount. Dosing liquid mercury is difficult to achieve accuracy, which leads to excessive use of mercury, which ultimately affects the environment.

The 19th International Conference on “Technical and Physical Problems of Engineering” (ICTPE-2023)

In an effort to improve the accuracy of mercury dosing, technical solutions based on the rejection of liquid dosing prevail. One such solution is the dosing of mercury in the solid state. The melting point of mercury is -38.9°C , so its use in the solid state requires the use of a special cryogenic installation. Although such a method can be implemented in principle, its application significantly complicates the lamp manufacturing technology.

In recent years, dosing of mercury in LL in the form of amalgams has become widespread. Amalgam is a solid or powdered combination of mercury with other metals. The amalgam is welded to the electrode assembly of the lamp and, due to heating with a high-frequency current, the amalgam is thermally decomposed and free mercury is released into the lamp. At the same time, it should be noted that the accuracy of mercury dosing using amalgam dispensers places high demands on their manufacture and the release of vaporous mercury inside the lamp. Installation of amalgam and its processing inside the lamp also complicates the LL manufacturing technology.

The 19th International Conference on “Technical and Physical Problems of Engineering” (ICTPE-2023)

A number of technical developments provide for the dosing of mercury in a liquid state enclosed in an ampoule or capsule. The required amount of mercury is placed in ampoules or capsules made of fusible material. An additional electrode is soldered into the stem. The capsule or ampoule is fixed on the stem using a metal plate and wire, which are welded to the holders of the electrode assembly. When the current source is turned on, the wire heats up and the capsule or ampoule is depressurized and mercury enters the lamp. With this technology, high dosing accuracy can be achieved with a very low mercury content (less than 3 mg). However, the placement of a strictly dosed amount of mercury in hermetically sealed ampoules or capsules with their installation inside the lamp, further destruction of the shell after the sealing of the lamp bulb also significantly complicates the technology and design of the lamp.

An analysis of existing dosing devices and methods for dosing mercury into LL in liquid and solid states shows that each direction has positive and negative sides. Dosing mercury in liquid state is difficult to achieve accurate dosage, which leads to excessive consumption of mercury, ultimately negatively affecting the environment. The introduction of mercury in the solid state reduces the excess consumption of mercury, however, this significantly complicates the technological process.

The 19th International Conference on “Technical and Physical Problems of Engineering” (ICTPE-2023)

The aim of the work is to develop effective methods for the dosing of mercury, the design of devices suitable for use in the production of LL.

FEATURES OF THE PROCESSES OF EVAPORATION AND CONDENSATION OF MERCURY IN LL

To analyze the processes of evaporation and condensation of mercury in LL, it is necessary to compare the number of molecules that have left the liquid and the number of molecules that condense in the presence of saturated vapor. Since the saturation vapor pressure is known, it is possible to count the number of vapor molecules hitting a unit surface area per unit time. According to the kinetic theory of gases, the indicated number of molecules is determined by formula:

$$N = \frac{1}{4} n \bar{v}$$

The 19th International Conference on “Technical and Physical Problems of Engineering” (ICTPE-2023)

where n is the concentration of vapor molecules; \bar{v} is the arithmetic mean velocity of molecules.

The mass of the above number of molecules can be determined by formula:

$$M_k = N \cdot m_0$$

or

$$M_k = \frac{1}{4} n \bar{v} \cdot m_0$$

where m_0 is the mass of one vapor molecule.

From the basic equation of the molecular kinetic theory, one can write:

$$n = \frac{P}{kT}$$

The 19th International Conference on “Technical and Physical Problems of Engineering” (ICTPE-2023)

That

$$M_k = \frac{1}{4} \cdot \frac{P}{kT} \sqrt{\frac{8kT}{\pi m_0}} \cdot m_0$$

or

$$M_k = P \sqrt{\frac{m_0}{2\pi kT}}$$

Let there be a hemispherical drop of mercury with mass M , its radius can be determined by formula:

$$r_1 = 3 \sqrt{\frac{3M}{2\pi\rho}}$$

and the evaporation surface can be defined as:

$$S = 2\pi \cdot r_0^2 = (2\pi)^{\frac{1}{3}} \cdot \left(\frac{3M}{\rho}\right)^{\frac{2}{3}}$$

The 19th International Conference on “Technical and Physical Problems of Engineering” (ICTPE-2023)

Considering that approximately 5 mg of mercury is introduced into the LL, calculations show that the radius of the mercury drop in the lamp is 0.56 mm. Smaller drops can also be present in the lamp, their evaporation rate is higher than the evaporation rate of large drops. Calculations show that the increase in pressure and, consequently, the evaporation rate for small drops is noticeable only when their sizes are less than 10^{-4} mm, for large drops, the increase in the evaporation rate due to the curvature of the phase interface is almost imperceptible.

RESEARCH RESULTS

The developed device consists of a reservoir partially filled with liquid mercury for its vaporous dosing into the LL (Figure 1).

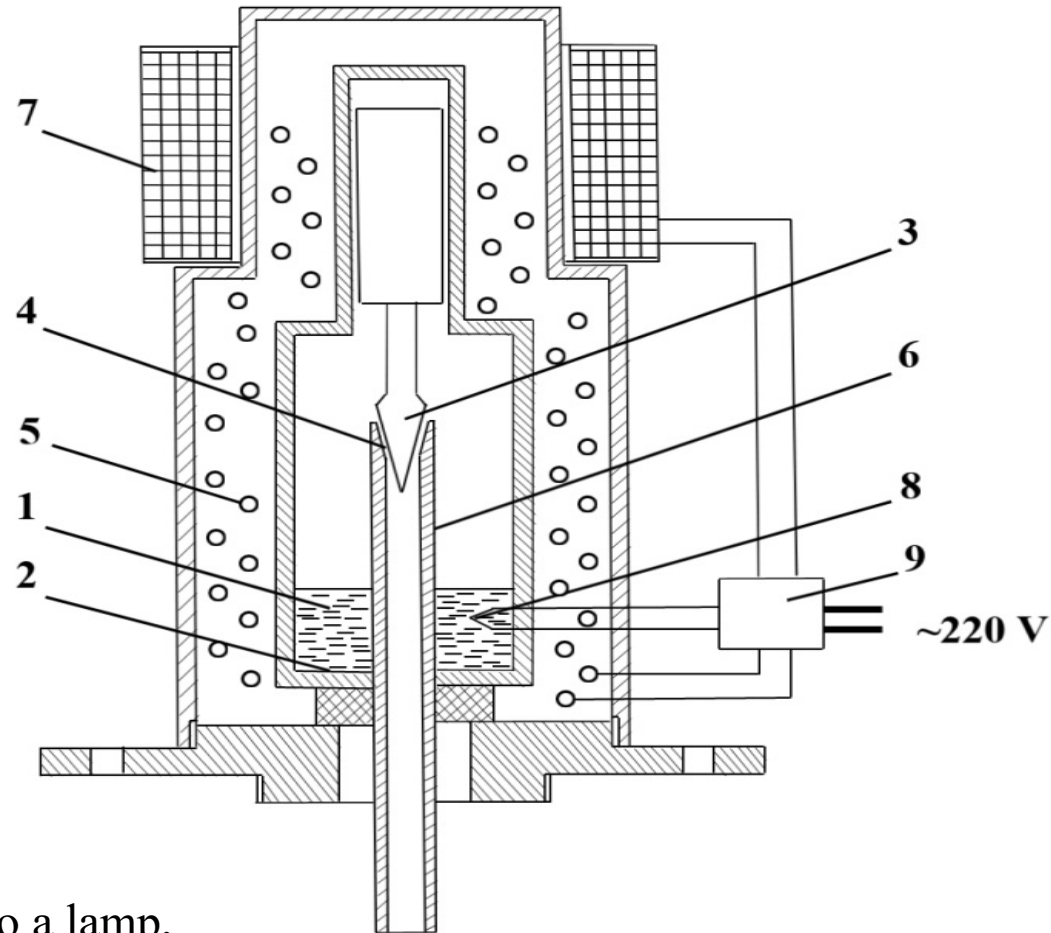

Figure 1. Device for dosing mercury into a lamp,
1: Reservoir for mercury, 2: Release hole, 3: Valve, 4: Cage,
5: Heater, 6: Branch pipe, 7: Electromagnetic coil,
8: Thermocouple, 9: Control block

The 19th International Conference on “Technical and Physical Problems of Engineering” (ICTPE-2023)

The device contains an electromagnetic valve, which is placed vertically and coaxially with the release hole, made in the lower part of the reservoir. A mercury heater and a vertical separating branch pipe are introduced into the device, the lower end of which is connected with the release hole. The valve cage is made at the upper end of the branch pipe. The coil of electromagnetic valve wraps around the top of the reservoir. Thermocouple, heater and coil of electromagnetic valve are connected to the control block.

To dose mercury into the lamp by using the heater, the mercury is heated to a temperature set by the control block, for example, up to 250°C. As a result of heating, mercury evaporates into the reservoir cavity, and the saturated vapor pressure in it increases.

Then voltage is applied to the coil of electromagnetic valve. At the same time, the valve rises out of the cage and the mercury vapor under the influence of the pressure difference (vacuum in the lamp) enters the lamp exhaust tube through the branch pipe. When passing inside the branch pipe, mercury vapor is accelerated by the pressure difference and exits as a beam, which enters the lamp through the exhaust tube. The mass of mercury entering the lamp is controlled by changing the temperature controlled by a thermocouple, as well as the duration of the voltage pulse applied to the coil of electromagnetic valve. If it is necessary to seal the valve, a spring can be additionally introduced into the device.

The 19th International Conference on “Technical and Physical Problems of Engineering” (ICTPE-2023)

CONCLUSION

1. Unlike dosing with a liquid supply of mercury, when it is supplied in a vapor state, the loss of mercury on the way to the lamp is practically excluded, since the volume of channels through which mercury is transferred to the lamp is many times smaller than the volume of the cavity of the lamp bulb;
2. Since the device and the mercury supply channels located in its immediate vicinity are at a higher temperature than the lamp, mercury condensation in the latter will occur more intensively, which contributes to the diffusion of mercury vapor from hotter parts into the colder cavity of the lamp;
3. Thanks to the supply of mercury in the vapor state, the device ensures its reliable supply to the lamp with sufficient dosage accuracy obtained by eliminating random factors that occur in the devices used with the supply of mercury to the lamp in a drop-liquid state;
4. Under special production conditions, on a prototype of a device for vaporous dosing of mercury in LL, in order to obtain reliable results, it is necessary to conduct fundamental studies of the modes of supplying mercury to the lamp;
5. Calculations of the processes of evaporation, condensation of mercury in a low-pressure LL can be used to evaluate and justify the rationality of methods for measuring the amount of mercury in a lamp, both in laboratory and in production conditions.