

UPQC CONTROL BASED ON MO-ADALINE APPROACH

A. Mokhtarpour H.A. Shayanfar S.M.T. Bathaee

*Department of Electrical Engineering, Science and Research Branch, Islamic Azad University, Tehran, Iran
 a.mokhtarpour@gmail.com, hashayanfar@yahoo.com, bathaee@kntu.ac.ir*

Abstract- In this paper power quality compensation in sag, swell, unbalance, and harmonized conditions have been done by the use of UPQC (Unified Power Quality Conditioner). It consists of two back to back connected Active Power Filters (APFs) with a common DC link. In the present research voltage problems are compensated by the Series Active Filter (SAF) of the UPQC. On the other hand, No.'s related to the compensation of current problems are done by the Parallel Active Filter (PAF) of UPQC. Related control approach is based on the Multi Output ADaptive LINear (MO-ADALINE) approach. Results are presented to confirm the validity of the proposed approach to achieve a high-quality output voltage and current.

Keywords: UPQC, MO-ADALINE, Power Quality.

I. INTRODUCTION

Nowadays, most of the equipments based on power electronic devices used by the industry, lead to power quality problems. These devices not only need high-quality energy to work properly but also are the major cause for decreasing power quality. In these conditions, both electric utilities and customers are increasingly affected from the quality of electric power. Between the different technical approaches available for the compensation of power quality problems, Active Power Filters (APFs) have an important alternative to compensate the power quality problems [1].

Different configurations of APFs can be found in [2]. One of the most efficient solution systems for power quality problems is Unified Power Quality Conditioner (UPQC). The used configurations consist of two shunt and series inverters as current and voltage compensators with a common dc link. Papers [3-19] use, different control systems to compensate the power quality problems of the grid, like current harmonics, reactive power and the source voltage distortions. The scope of this research is to use UPQC for improvement of power quality and main principle of the proposed control theory is based on MO-ADALINE approach. Simplicity and flexibility in extraction of different reference signals can be one of the proposed algorithm advantages.

Section II generally introduces UPQC. Section III explains proposed control algorithm. Section IV simulates paper. Finally section V concludes the results.

In [20], neutral current in three phase four wire systems is compensated by using a four leg PAF for the UPQC. In [21], UPQC is controlled by H_∞ approach which needs high calculation demand. In [22], UPQC can be controlled based on the phase angle control for shared load reactive power between SAF and PAF. In [23] minimum active power injection has been used for SAF in a UPQC-Q, based on its voltage magnitude and phase angle ratings in sag conditions. In [24], a DG has been used as an energy resource for the UPQC. In [25-27] two new combinations of SAF and PAF for two independent distribution feeders power quality compensation have been proposed.

II. UNIFIED POWER QUALITY CONDITIONER

UPQC has composed of two inverters that are connected back to back. One of them is connected to the grid via a parallel transformer and can compensate the current problems. Another one is connected to the grid via a series transformer and can compensate the voltage problems. These inverters are controlled for the compensation of the power quality problems instantaneously.

The shunt APF which acts as a current source inverter is responsible for load current harmonics compensation as well as reactive power. It is connected to the grid via a second order LC filter and parallel star connection transformer. Also, the series PAF which acts as voltage source inverter is responsible for source voltage sag, swell, unbalance and harmonics compensation. It is connected to the grid via a second order low pass LC filter and three series single phase transformer.

Figure 1 shows the general schematic of a UPQC. Second order filters are used to omit the inverter switching frequencies.

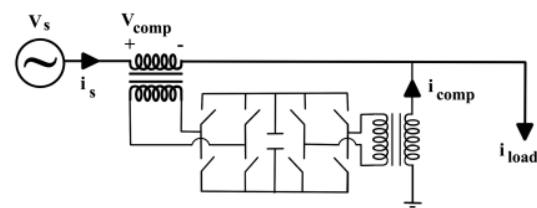

Figure 1. General schematic of a UPQC

A simple circuit model of the UPQC is shown in Figure 2. Series active filter can be modeled as the voltage source and parallel active filter can be modeled as the current source. Related Kirchoff's current and voltage laws are as Equation (1).

$$\begin{aligned} i_s &= i_L - i_{sh} \\ v_s &= v_L + v_{se} \end{aligned} \quad (1)$$

where, i_{sh} is the shunt APF current and v_{se} is the series APF voltage.

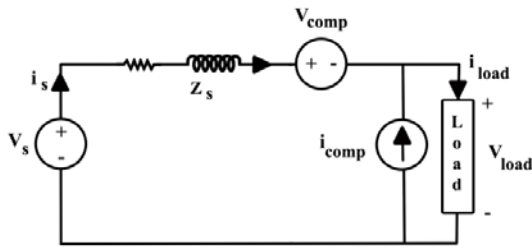

Figure 2. Circuit model of the UPQC

In this paper, the series APF operates as a controlled voltage source arranging the load voltage sinusoidal and at a predetermined constant voltage level. As mentioned earlier in this control approach, series active filter can compensate harmonics as well as voltage sag and swells. Proposed approach can be used for the extraction of direct and indirect first order components of the source side voltage. Thus the magnitude of the reference load side voltage can be setup to the nominal value for generation of desired load voltage. The series APF injects compensator voltage which is a voltage equal to the difference of the desired load voltage and the supply voltage to the grid.

III. PROPOSED CONTROL STRATEGY

Based on MO-ADLINE each $n \times 1$ signal of y can be written as a weighted linear combination of its components. If $S(t)$ be $n \times m$ component matrix of y at time t and $W(t)$ be $m \times 1$ vector of weighted coefficient then, the signal of y can be written as Equation (2). MO-ADLINE can be used for determining weight vector of W which generates a special signal of y from its components [3]. Weighted factors can be updated in each stage of an adaptation approach for extraction of a desired signal. Equation (2) shows adaptation rule that is based on Least Mean Square (LMS) algorithm.

$$y = SW \quad (2)$$

$$W(t + dt) = W(t) + kS^T(t)[S(t)S^T(t)]^{-1}e(t)$$

where, $e(t)$ is the error between desired and actual signal of y and k is the convergence factor. It is possible to extract the reference voltage and current from uncompensated source voltage and load current. Fourier coefficients can be determined as vector of y . Reference signal can be determined as W . Matrix of S is constant. After determination of uncompensated signal Fourier coefficients, they can be compared with the desired values. Error signal can be used in adaptation rule for updating the vector of W .

Therefore, reference voltage and current can be determined. For capability of compensation in dynamic condition moving average window Fourier transform has been used for extraction of coefficients. Figure 3 shows block diagram of the proposed MO-ADLINE approach. In the proposed control system there is a data window with the length of the main period of power system which is moved to the right by new data interring for the extraction of the Fourier transforms. This is because of mathematical calculation reduction.

$$y = \begin{bmatrix} a_n \\ b_n \\ a_0 \end{bmatrix} \quad (3)$$

$$S(t) = \frac{2}{m-1} \begin{bmatrix} \cos(n\omega t_0) & \cos(n\omega t_1) & \dots & \cos(n\omega t_{m-1}) \\ \sin(n\omega t_0) & \sin(n\omega t_1) & \dots & \sin(n\omega t_{m-1}) \\ \frac{1}{2} & \frac{1}{2} & \dots & \frac{1}{2} \end{bmatrix} \quad (4)$$

$$W = \begin{bmatrix} w(t_0) \\ w(t_1) \\ \dots \\ w(t_{m-1}) \end{bmatrix} \quad (5)$$

$$\begin{bmatrix} a_n \\ b_n \\ a_0 \end{bmatrix} = \frac{2}{m-1} \begin{bmatrix} \cos(n\omega t_0) & \dots & \cos(n\omega t_{m-1}) \\ \sin(n\omega t_0) & \dots & \sin(n\omega t_{m-1}) \\ \frac{1}{2} & \dots & \frac{1}{2} \end{bmatrix} \begin{bmatrix} w(t_0) \\ w(t_1) \\ \dots \\ w(t_{m-1}) \end{bmatrix} \quad (6)$$

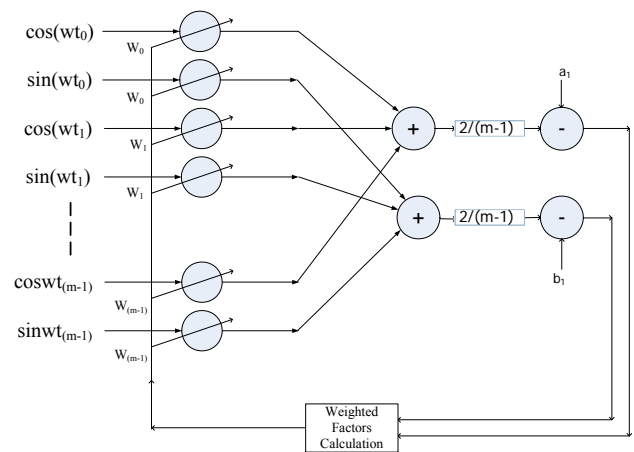

Figure 3. Block diagram of the proposed MO-ADLINE approach

IV. RESULTS

For the investigation of the validity of the mentioned control strategy for power quality compensation of a distribution system, simulation of the test circuit of Figure 1 has been done in MATLAB software. Source current and load voltage have been measured and analyzed in the proposed control system for the determination of the compensator signals of SAF and PAF. Related equations of the controlled system have been compiled in MATLAB software via M-file.

Desired values of a_n and b_n are determined in the proposed algorithm for extraction of the reference signals. Simplicity and flexibility in extraction of different reference signals can be one of the proposed algorithm advantages.

In the mentioned control strategy, voltage problems have been compensated by SAF of the UPQC and current problems have been compensated by PAF of the UPQC. The power system consists of a harmonized and unbalanced three phase 380 V (RMS, L-L), 50 Hz utility, a three phase rectifier as a nonlinear load, a three phase balanced R-L load which is connected to the circuit at 0.04 sec and a one phase load which is connected to the circuit at 0.07 sec.

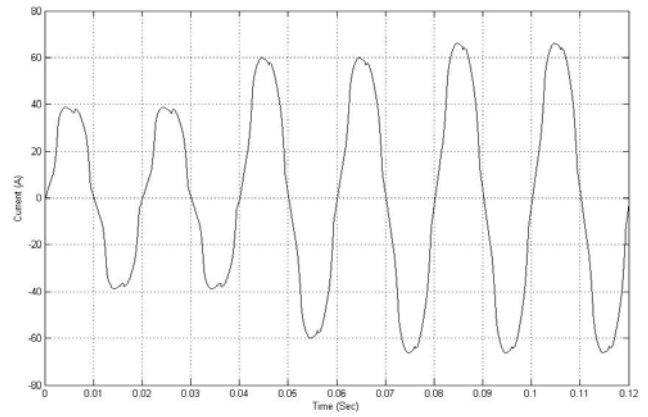

Figure 7. Load side current of phase 1

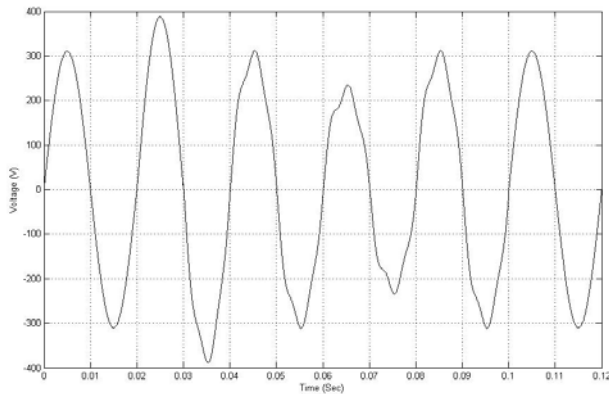

Figure 4. Source side voltage of phase 1

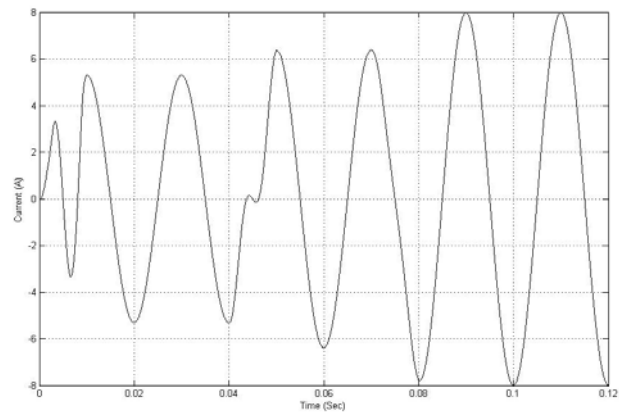

Figure 8. Reactive current of phase 1

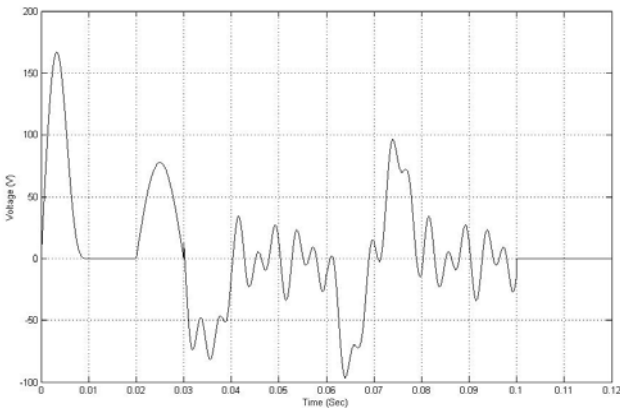

Figure 5. Compensator voltage of phase 1

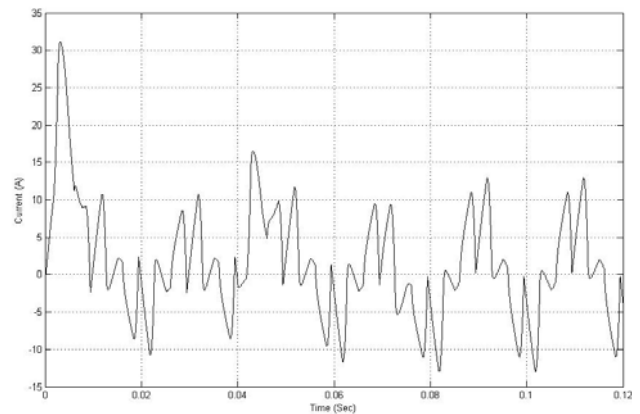

Figure 9. Harmonic current of phase 1

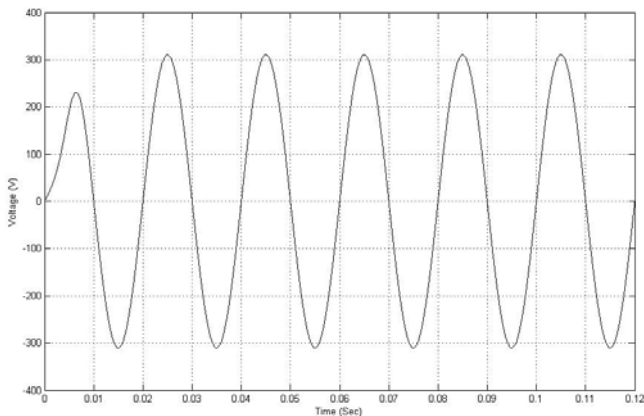

Figure 6. Load side voltage of phase 1

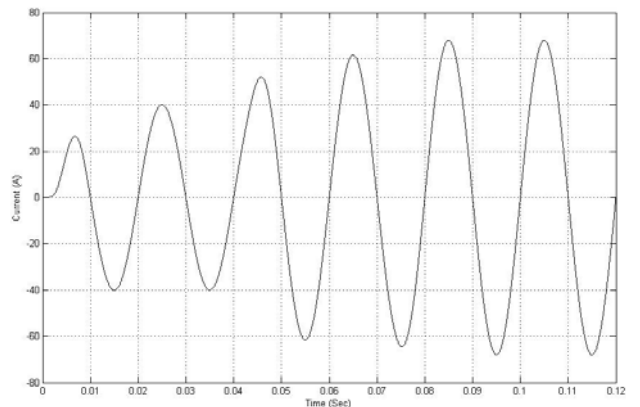

Figure 10. Source side current of phase 1

For the investigation of the voltage harmonic condition, utility voltages have harmonic and negative sequence components between 0.03 sec and 0.1 sec. Also, for the investigation of the proposed control strategy in unbalance condition, magnitude of the first phase voltage is increased to the 1.25 pu between 0.02 sec and 0.04 sec and decreased to the 0.75 pu between 0.06 and 0.08 sec.

A number of selected results will be showed further. Figure 4 shows the source side voltage of phase 1. Figure 5 shows the compensator voltage of phase 1. Figure 6 shows load side voltage of phase 1. Figure 7 shows the load side current of phase 1. Figure 8 shows the reactive current of phase 1. Figure 9 shows the harmonic current of phase 1. Finally, Figure 10 shows the source side current of phase 1. Table 1 shows THDs of source and load voltages and currents. Load voltage and source current harmonics have been compensated satisfactory.

Table 1. Total Harmonic Distortion (THD)

Source Voltage THD	Load Current THD	Load Voltage THD	Source Current THD
0.17	0.12	Almost zero	Almost zero

V. CONCLUSIONS

It is known that active filters are generally used for compensation of voltage and current problems in distribution systems. In this paper power quality compensation has been done by the use of UPQC. The related proposed control algorithm based on MO-ADALINE approach has been compiled in MATLAB software via M-File. Voltage harmonics have been compensated by SAF of the UPQC and current harmonics have been compensated by PAF of the UPQC. Based on the results proposed strategy not only can generate pure sinusoidal source current and load voltage but also can compensate source reactive power satisfactory. Total harmonic distortion of load voltage before compensation was 0.17 which was reduced to almost zero after the compensation. Also, total harmonic distortion of the source current before compensation was 0.12 which was reduced to almost zero after the compensation.

NOMENCLATURES

- i_L : The load current
- v_s : The source current
- $S(t)$: $n \times m$ component matrix at time t
- $W(t)$: $m \times 1$ vector of weighted coefficient
- $e(t)$: The error between desired and actual signal

REFERENCES

[1] I. Axente, J.N. Ganesh, M. Basu, M.F. Conlon, K. Gaughan, "A 12-kVA DSP-Controlled Laboratory Prototype UPQC Capable of Mitigating Unbalance in Source Voltage and Load Current", IEEE Transactions on Power Delivery, Issue 6, Vol. 25, pp. 1471-1479, 2010.
 [2] A. Ghosh, G. Ledwich, "Power Quality Enhancement Using Custom Power Devices", MA: Kluwer, Boston, USA, 2002.
 [3] M.I. Arei, E.F. El-saadany, M.M. Salama, "A Novel Control Algorithm for the DG Interface to Mitigate

Power Quality Problems", IEEE Transaction on Power Delivery, Issue 3, Vol. 19, pp. 1384-1392, July 2004.
 [4] H. Heydari, A.H. Moghadasi, "Optimization Scheme in Combinatorial UPQC and SFCL Using Normalized Simulated Annealing", IEEE Transactions on Power Delivery, Issue 3, Vol. 26, pp. 1489-1498, 2011.
 [5] H. Fujita, H. Akagi, "The Unified Power Quality Conditioner: The Integration of Series and Shunt Active Filters", IEEE Transaction on Power Electronics, Issue 3, Vol. 13, pp. 315-322, 1998.
 [6] M.A. Hannan, A. Mohamed, "PSCAD/EMTDC Simulation of Unified Series-Shunt Compensator for Power Quality Improvement", IEEE Transaction on Power Delivery, Issue 2, Vol. 20, pp. 1650-1656, 2005.
 [7] L.H. Tey, P.L. So, Y.C. Chu, "Unified Power Quality Conditioner for Improving Power Quality Using ANN with Hysteresis Control", Int. Conf. on Power System Technology (PowerCon), Vol. 2, pp. 1441-1446, 2004.
 [8] S.B. Karanki, M.K. Mishra, B.K. Kumar, "Particle Swarm Optimization-Based Feedback Controller for Unified Power-Quality Conditioner", IEEE Transactions on Power Delivery, Issue 4, Vol. 25, 2010.
 [9] L.H. Tey, P.L. So, Y.C. Chu, "Neural Network Controlled Unified Power Quality Conditioner for System Harmonic Compensation", IEEE Power Eng. Soc. Transmission and Distribution Conf. and Exhibit. Asia Pacific, Vol. 2, pp. 1038-1043, October 2002.
 [10] H.A. Shayanfar, A. Mokhtarpour, "Management, Control and Automation of Power Quality Improvement", INTECH Book Company, Austria, 2010.
 [11] H.A. Shayanfar, N.M. Tabatabaei, A. Mokhtarpour, "Best Control Strategy for Unified Power Quality Conditioner (UPQC) Based on Simulation", The IASTED International Conference on Power and Energy Systems (PES 2007), pp. 257-262, Clearwater, Florida, USA, January 2007.
 [12] A. Kazemi, A. Mokhtarpour, M. Tarafdard Haque, "A New Control Strategy for Unified Power Quality Conditioner (UPQC) in Distribution Systems", IEEE International Conference on Power System Technology (POWERCON 2006), pp. 1-5, October 2006.
 [13] H.A. Shayanfar, N.M. Tabatabaei, A. Mokhtarpour, "Modified Strategy for Unified Power Quality Conditioner (UPQC) Based on Intelligent Devices", The Ninth World Multiconference on Systemic, Cybernetics and Informatics, Vol. IX, pp. 13-17, Orlando, Florida, USA, July 2005.
 [14] M.J. Newman, D.G. Holmes, J.G. Nielsen, F. Blaabjerg, "A Dynamic Voltage Restorer (DVR) with Selective Harmonic Compensation at Medium Voltage Level", IEEE Transaction on Ind. Appl., Issue 6, Vol. 41, pp. 1744-1753, Nov./Dec. 2005.
 [15] J.G. Nielsen, F. Blaabjerg, "A Detailed Comparison of System Topologies for Dynamic Voltage Restorers", IEEE Transaction on Industrial Applications, Issue 5, Vol. 41, pp. 1272-1280, Sep./Oct. 2005.
 [16] J.G. Nielsen, M. Newman, H. Nielsen, F. Blaabjerg, "Control and Testing of a Dynamic Voltage Restorer (DVR) at Medium Voltage Level", IEEE Trans. on Power Electronic, Issue 3, Vol. 19, pp. 806-813, May 2004.

- [17] M.J. Newman, D.N. Zmood, D.G. Holmes, "Stationary Frame Harmonic Reference Generation for Active Filter Systems", IEEE Transaction on Industrial Applications, Issue 6, Vol. 38, pp. 1591-1599, Nov./Dec. 2002.
- [18] M. Tarafdar Hagh, A. Roshan Milani, M.R. Azimzadeh, "Investigation of Harmonic Current Source Effects on Distribution and Transmission Lines Capacity and Losses: Case Study", International Journal on Technical and Physical Problems of Engineering (IJTPE), Issue 8, Vol. 3, No. 3, pp. 81-85, September 2011.
- [19] H. Jangi Bahador, "Design and Implementation of Power Factor Correction (PFC) Converter with Average Current Mode Control Using DSP", International Journal on Technical and Physical Problems of Engineering (IJTPE), Issue 6, Vol. 3, No. 1, pp. 92-95, March 2011.
- [20] V. Khadkikar, A. Chandra, "A Novel Structure for Three Phase Four Wire Distribution System Utilizing Unified Power Quality Conditioner (UPQC)", IEEE Transactions on Industry Applications, Issue 5, Vol. 45, pp. 1897-1902, 2009.
- [21] K.H. Kwan, Y.C. Chu, P.L. So, "Model-Based H ∞ Control of a Unified Power Quality Conditioner", IEEE Transactions on Industrial Electronics, Issue 7, Vol. 56, pp. 2493-2504, 2009.
- [22] V. Khadkikar, A. Chandra, "A New Control Philosophy for a Unified Power Quality Conditioner (UPQC) to Coordinate Load-Reactive Power Demand Between Shunt and Series Inverters", IEEE Transaction on Power Delivery, Issue 4, Vol. 23, pp. 2522-2534, 2008.
- [23] W.C. Lee, D.M. Lee, T.K. Lee, "New Control Scheme for a Unified Power Quality Compensator-Q with Minimum Active Power Injection", IEEE Transaction on Power Delivery, Issue 2, Vol. 25, pp. 1068-1076, 2010.
- [24] B. Han, B. Bae, H. Kim, S. Baek, "Combined Operation of Unified Power Quality Conditioner with Distributed Generation", IEEE Transaction on Power Delivery, Issue 1, Vol. 21, pp. 330-338, 2006.
- [25] H.R. Mohammadi, A.Y. Varjani, H. Mokhtari, "Multiconverter Unified Power-Quality Conditioning System: MC-UPQC", IEEE Transaction on Power Delivery, Issue 3, Vol. 24, pp. 1679-1686, 2009.
- [26] A.K. Jindal, A. Ghosh, A. Joshi, "Interline Unified Power Quality Conditioner", IEEE Transaction on Power Delivery, Issue 1, Vol. 22, pp. 364-372, 2007.
- [27] A. Mokhtarpour, H.A. Shayanfar, N.M. Tabatabaei, "Power Quality Compensation in Two Independent Distribution Feeders", International Journal for Knowledge, Science and Technology, Vol. 1, No. 1, pp. 98-105, 2009.

BIOGRAPHIES



Ahad Mokhtarpour was born in Tabriz, Iran, 1979. He received the B.S. degree from University of Tabriz, Tabriz, Iran and M.S.E. degree from Iran University of Science and Technology, Tehran, Iran all in Electrical Engineering in 2003 and 2005, respectively. Currently he is a

Ph.D. student in Islamic Azad University, Science and Research Branch, Tehran, Iran. His research interests are in the power quality compensation, distribution network control and reliability.



Heidar Ali Shayanfar was born in Zabol, Iran, 1951. He received the B.S. and M.S.E. degrees in Electrical Engineering in 1973 and 1979 and the Ph.D. degree in Electrical Engineering from Michigan State University, U.S.A., in 1981. Currently, he is a Full Professor in

Electrical Engineering Department at Iran University of Science and Technology University, Tehran, Iran. His research interests are in the application of artificial intelligence to power system control design, dynamic load modeling, power system observability studies and voltage collapse. He is a member of Iranian Association of Electrical and Electronic Engineers (IAEEE) and IEEE. He has published more than 385 papers in the international journals and conferences proceedings.



Seyed Mohammad Taghi Bathaee was born in Iran, July 1950. He received the B.Sc., B.Sc., M.Sc. and Ph.D. degrees in Math. and Electrical Engineering from K.N. Toosi University (Tehran, Iran), Tehran University (Tehran, Iran), George Washington University (USA) and

Amir Kabir University (Tehran, Iran), respectively. His research interest is in power system analysis and control. Currently, he is head of Power System Section at K.N. Toosi University (Tehran, Iran).