

MEASUREMENT OF TRANSFER IMPEDANCE AND SCREENING ATTENUATION EFFECTS ON CABLES USING TRI-AXIAL METHOD

N. Akcam M.H. Karatas

*Electrical and Electronics Engineering Department, Gazi University, Ankara, Turkey,
ynursel@gazi.edu.tr, merveolmez@hotmail.com*

Abstract- Cables are an essential part of any electrical and electronics systems. Transfer impedance of cables characterizes basic parameters of electromagnetic compatibility like immunity and radiation on cables. In this study, experiment of transfer impedance measurement has been performed to express screening efficiency using tri-axial method on cables according to EN ISO 50289-1-6 standard. On the other hand transfer impedance has been analyzed mathematically and obtained results have been simulated via Simulink and Matlab. Acquired simulation results and experiment results have been compared comprehensively.

Keywords: Electromagnetic Compatibility, EMC, Transfer Impedance, Screening Attenuation, Tri-axial method.

I. INTRODUCTION

Electromagnetic Interference (EMI) event emerge with interaction of devices each other or electromagnetic noise at environment. Under electromagnetic interference (EMI), devices on daily life exhibits different behavior from expected characteristics. Also EMI decreases performance of devices and systems.

Transfer impedance is the rate of voltage to current which induced at the cable screen and flow inside of cables respectively. Transfer impedance characterizes basic parameters of electromagnetic compatibility as radiation and immunity. For the first time in 1934 scientist Schelkunoff defined transfer impedance at the Bell Laboratory.

In this paper, the testing system, which is composed of the tri-axial device, is design to measure the transfer impedance of the cable. Using this testing system, the transfer impedance can be measured by a network analyzer. Measurement methods of screening efficiency have been mentioned and for that purpose measurement experiment of transfer impedance which is the most used parameters defining electromagnetic compatibility has been performed. Transfer impedance has been calculated mathematically and results have been simulated using Matlab and Simulink. Besides simulation results and experiment results have been compared comprehensively.

II. EXPERIMENT OF SCREENING EFFICIENCY AND ELECTROMAGNETIC COMPATIBILITY ON CABLES

In the standard of TS EN 50289-1-6 "Cables-Communication cables-Specification for test method (Part1-6) Electrical test methods-electromagnetic performance", which was firstly prepared in 2002 by CENELEC about tests applied on electromagnetic compatibility of communication cables and was later published in 2006 by TSE, four different methods that were defined in order to specify electromagnetic compatibility of especially communication cables are described [1]. Methods have been developed for measurement of screening attenuation, transfer impedance and screening quality for electromagnetic compatibility on cables. There are four different methods to determine electromagnetic compatibility on cables used in communication systems.

1. Transfer Impedance, Tri-axial Method,
2. Transfer Impedance, Line Injection Method,
3. Screening Attenuation, Tri-axial Method,
4. Coupling attenuation and Screening attenuation, Absorbing Clip Method.

As seen from experiment methods, quality of screening on cables in the sense of EMC is determined by measurement of transfer impedance and screening attenuation.

A. Transfer Impedance on Cables

Electromagnetic field coupling causes I_e interference current at the screen area of cables. I_e current generates electromagnetic field which cause interference with the source electromagnetic field of this current. Some part of this electromagnetic field is reflected by screen. Also some part of it is transmitted at the screen due to skin effect. Transmitted electromagnetic field causes I_i current loop. As a result of this, V_i voltage is detected between screen and inner conductor. The less this voltage is, the better screening quality can be obtained by means of screening efficiency in quantity. Another parameter that should be taken into account to measure screening quality of cable is Z_T transfer impedance. Because this parameter is obtained from the ratio of V_i voltage to I_e current. If I_e current flows on screen, Z_T value of the cable with high

screening efficiency becomes very low, and this shows that screening performance of cable is extremely good. Transfer impedance is the parameters that can measure the ability of protect outer conductor or transmission line of screen against any electromagnetic field [2].

B. Physical Implementation of Transfer Impedance Measurement Using Tri-axial Method

Transfer impedance measurement setup is illustrated in Figure 1 and the components are listed below.

- a) A network analyzer,
- b) Tri-axial tube and network analyzer ended by cable screen. The material of the tube should be a good conductor. For example, non-ferromagnetic materials like brass are used.
- c) Printer,
- d) Impedance matching circuit if needed.

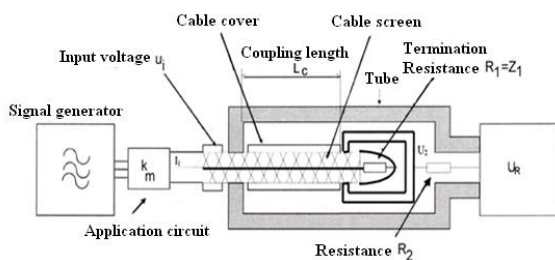

Figure 1. Measurement setup

Experiment sample is connected to the generator, outer circuit (tube), and receiver. Attenuation, $a_{measurement}$, is measured by screening logarithmic frequency along all the concerned frequency period for transfer impedance.

$$a_{measurement} = 20 \times \log_{10} \left| \frac{U_{F,measurement}}{U_{R,measurement}} \right| \quad (1)$$

where U_F is measurement voltage that supplies the cable under test during measurement operation and U_R is measurement voltage in receiver during measurement operation. Experiment setup, comes from the equation below;

$$Z_T L_c = \frac{U_2}{I_1} = \frac{R_1 \times (50 + R_2)}{50 k_m} \times \frac{U_R}{U_{F,measurement}} \quad (2)$$

In this equation, U_2 is the voltage in outer system and I_1 is the current in the inner system.

$$Z_T = \frac{R_1 \cdot (50 + R_2)}{50 \cdot k_m \cdot L_c} \cdot 10^{\left\{ \frac{a_{measurement} - a_{cal}}{20} \right\}} \quad (3)$$

$$L_c \leq -50 \times 10^6 / \sqrt{\epsilon_{r1}} f_{max} \quad (4)$$

$$f_{max} \leq 167 \times 10^6 / \sqrt{\epsilon_{r1}} \quad (5)$$

The parameters used in Equations (2)-(5) are defined as;

- U_i : Voltage entering the inner system,
- Z_T : Transfer impedance,
- $a_{measurement}$: Attenuation measured, during measurement operation,
- a_{cal} : Composite loss measured during calibration operation,
- L_c : Maximum coupling length,
- R_1 : Ending resistance in inner system,

- R_2 : Serial resistance in outer system,
- k_m : Voltage gain of matching circuit
- ϵ_{r1} : Relative permittivity of cable

Transfer impedance values are expressed as Z_T for unit length in frequencies for specifications defined in the relevant cable standards [1, 2]. The test set-up shown in Figure 2 was prepared in laboratory for tri-axial method. Measurement results were obtained by running circuit analyzer and WinComet program.



Figure 2. Connecting test setup to circuit analyzer with WinComet program

In Figure 3, the transfer impedance Z_T of the cable is about (0-500) mΩ/m in the frequency range of (4-82.6) MHz, and Z_T increases with the frequency obviously. In figure, the transfer impedance was found 250 mΩ/m at about 30MHz. Changes in transfer impedance to frequency for RG 058 antenna cable can be seen in Figure 4.

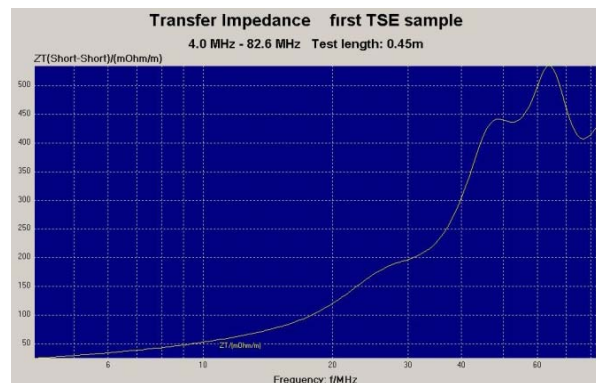

Figure 3. Frequency response of transfer impedance of sample cable



Figure 4. Frequency response of RG 058 antenna cable transfer impedance

C. Screening Attenuation

The screening attenuation, a_s is defined as the logarithmical ratio of source power (P_s) to the reflected maximum power ($P_{r,max}$) in the circuit [3, 4]. Thus the screening attenuation has to be calculated by:

$$a_s = 10 \cdot \log_{10} \left| \frac{P_s}{P_{r,max}} \right| \quad (6)$$

It is important that screening attenuation on transfer impedance measurements. It is difficult to use a screened cable without connectors. Hence the screening performance of connectors should be no worse than that needed of the cable to which they are attached. It is convenient to consider their screening under several headings:

- (a) the mating face,
- (b) the connector body,
- (c) the braid clamp or,
- (d) the body-to-panel joint,
- (e) the back-shell to connector joint.

Frequency response of transfer impedance with screening attenuation (a_s) effects for sample cable are shown in Figure 5-6.

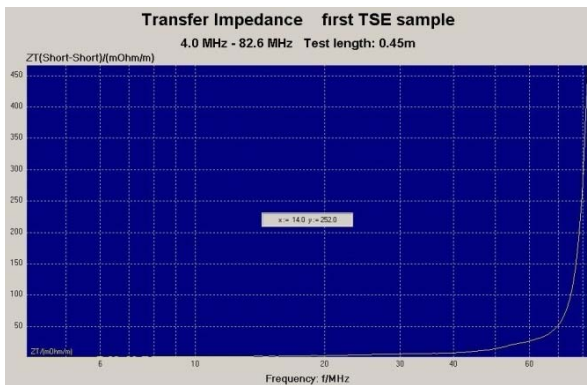

Figure 5. Effects of screening attenuation on transfer impedance for sample cable

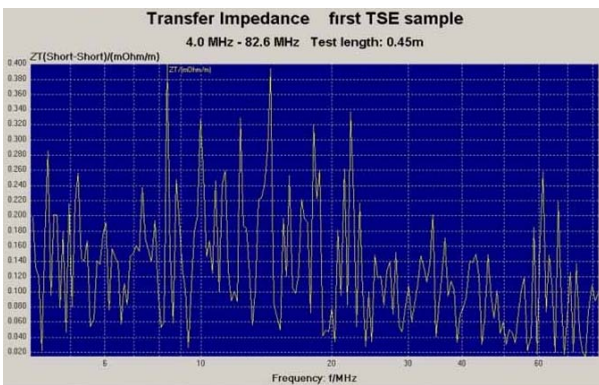

Figure 6. Effects of screening attenuation on transfer impedance for sample cable (in detail)

III. CALCULATION AND SIMULATION OF TRANSFER IMPEDANCE

The typical road that transfer impedance of a cable of which braid screen structure is shown in Figure 7, traces can be seen in Figure 8 [5].

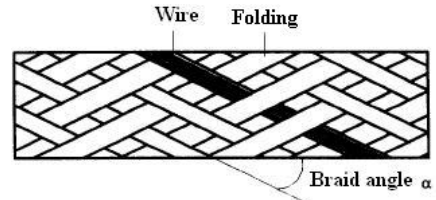

Figure 7. Structure of Braid Screening

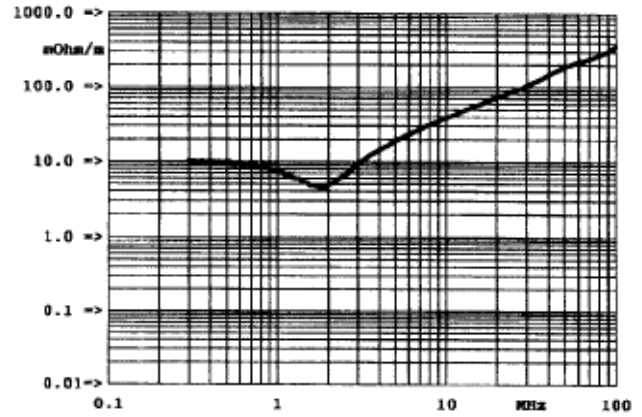

Figure 8. The ordinary road traced by transfer impedance of a braid screened cable [11]

Several researches have been carried out on modeling of transfer impedance measurement. Kaden [6] started his search on calculating transfer impedance with holed tube. In another work, Vance [7] applied elliptical shaped holes instead of round holes. Tyni [8] and Tsaliowich [9] separated braid layer into 2 parts. In addition to the models mentioned above, different models on calculating transfer impedance of cable were developed (Sali [10], Zhou and Gong [11] and so on). Most of these models mentioned above are created with little differences and changes.

Tyni [8] proposed a simple and clear model for transfer impedance calculation. According to this model, leakage along the braid which increases transfer impedance in high frequencies is caused by two inductances. These are inductances of braid and leakage. Braid inductance L_b is a result of textile nature of braid and leakage inductance L_h is caused by holes of braid.

$$L_b = \frac{\mu_o h}{4\pi D_m} (1 - \tan^2 \alpha) \quad (7)$$

$$L_h = \frac{\mu_o 2N}{\pi \cos \alpha} \left(\frac{b}{\pi D_m} \right)^2 \exp \left(\frac{-\pi d}{b} - 2 \right) \quad (8)$$

where;

α : Braid angle

D_m : Mean braid diameter

b : Hole width

d : Braid-wire diameter

h : Radial spindle separation

μ_o : Permeability

N : Number of folding

Braid parameters: Length of spindle l , braid diameter D_0 , wire diameter, number of folding and number of wire per folding n defined in producer's catalogue are used in order to calculate L_b and L_h in Equations (7) and (8). Using these values obtained from the catalogues parameters of $D_m, b, \tan \alpha, h$ are calculated.

$$D_m = D_0 + 2d \tag{9}$$

$$b = \frac{2\pi D_m}{N} \cos \alpha - nd \tag{10}$$

$$\tan \alpha = \frac{\pi D_m}{l} \tag{11}$$

$$h = \frac{2d^2}{b+d} \tag{12}$$

According to Tyni's model the approximate value of transfer impedance is;

$$Z_T \cong R + j\omega(L_h - L_b) \tag{13}$$

Matlab and Simulink software have been used to compare results between experimental results obtained

previous section and calculated results for transfer impedance. As a test sample (Figure 9), RG-058 cable has been used and required production parameters have been taken from producer data sheet as; $l = 11.0 \text{ mm}$, $D_0 = 2.95 \text{ mm}$, $d = 0.114 \text{ mm}$, $N = 16$, $n = 5$ and $\mu_0 = 4\pi 10^{-7} \text{ H/m}$.

At Figure 10, frequency-transfer impedance variation of RG-058 cable is seen by using tri-axial method in the experiment. As seen by figure DC resistance of cable is approximately $15 \text{ m}\Omega$. On the other hand, simulation result has been given using same cable and Tyni's method at the Figure 11. Calculation block has been composed via Simulink software. User can change input parameters if required, and results can be plotted graphically.

As seen the figures, measurement results and Tyni's calculation results are very similar. Tyni's proposed method plots raising linear line at the high frequencies.

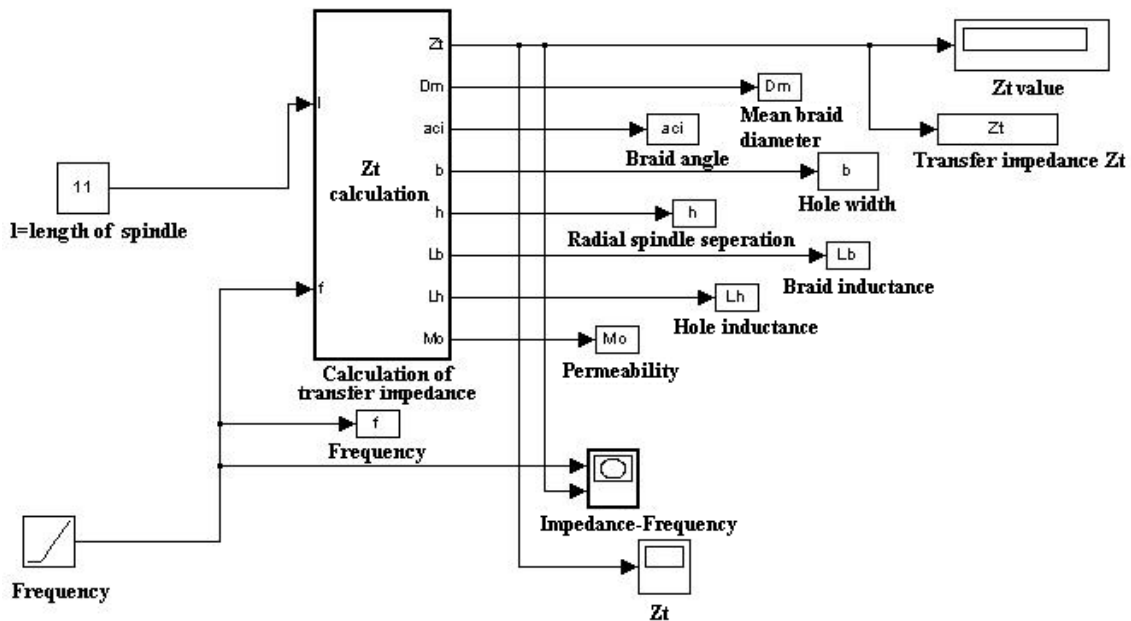

Figure 9. Simulink- calculation block of transfer impedance



Figure 10. RG-058 cable-Transfer impedance-frequency variation using tri-axial method

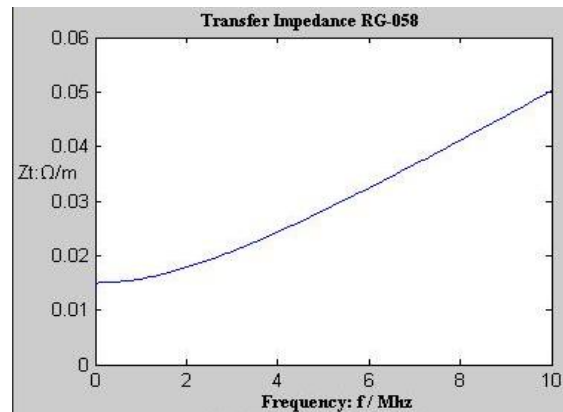

Figure 11. Transfer impedance-frequency variation using simulation result

IV. RESULTS

Up to now, the measurement of the transfer impedance Z_T and the effect of screening attenuation a_s on Z_T required the tri-axial set-up. Measurement and calculation of Z_T show that transfer impedance changes with frequency for braided cables. Z_T is not small as ignorable value at the radio frequencies. At low frequencies transfer impedance equals to DC resistance value, at high frequencies curve of transfer impedance bends to up and rises like smooth line.

At sufficient high frequencies, resistive component R can be ignored. Small transfer impedance Z_T means that low leakage and high electromagnetic compatibility. As a result, tri-axial method which is defined at the standard to be able to measure electromagnetic compatibility has been studied and performed at the test laboratory. It has been seen that experimental results and calculated results were consistent.

REFERENCES

- [1] TS EN 50289-1-6, "Cables, Communication Cables, Test Methods for the Specification - Part 1-6: Electrical Test Methods, Electromagnetic Performance", 2006 (in Turkish).
- [2] M. Bluhm, E. Perogli, G. Pierucci, V. Squizzato, R.R. Zich, "Measurements of Transfer Impedance with the Line Injection Method on Cables and Connectors", IEEE International Symposium, Vol. 2, 21-25, pp. 599-604, August 2000.
- [3] M.T. Hagh, A.R. Milani, M.R. Azimzadeh, "Investigation of Harmonic Current Source Effects on Distribution and Transmission Lines Capacity and Losses: Case Study", International Journal on Technical and Physical Problems of Engineering (IJTPE), Issue 8, Vol. 3, No. 3, pp. 81-85, September 2011.
- [4] H. Shayeghi, M. Mahdavi, "Studying the Effect of Losses Coefficient on Transmission Expansion Planning Using Decimal Codification Based GA", International Journal on Technical and Physical Problems of Engineering (IJTPE), Issue 1, Vol. 1, No. 1, pp. 58-64, December 2009.
- [5] M. Kirschvink, P. Vroomen, "Optimal Cable Screening Braids Determined by a Computer Aided Statistical Planning Method", IEEE International Symposium on Compatibility in the Loop, pp. 31-36, 1994.

[6] H. Kaden, "Eddy Currents and Shielding in the Message Technology", Springer Verlag, 1959 (in German).

[7] E.F. Vance, "Shielding Effectiveness of Braided Wire Shields", IEEE Trans. on Electromagnetic Compatibility, EMC-Vol. 17, pp. 71-70, 1975.

[8] M. Tyni, "The Transfer Impedance of Coaxial Cables with Braided Outer Conductor", Inst. Telek. Politech, 1976.

[9] A. Tsaliowich, "Braided Shield Engineering Model: Shielding and Transmission Performance, Optimal Design", Optimal Design International, Wire and Cable Symposium, 1981.

[10] S. Sali, "An Improved Model for the Transfer Impedance Calculations of Braided Coaxial Cables", IEEE Trans. on Electromagnetic Compatibility, Vol. 33, No. 2, pp. 139-143, May 1991.

[11] G. Zhou, L. Gong, "An Improved Analytical Model for Braided Cable Shields", IEEE Trans. on ENMC, Vol. 32, No. 2, pp. 161-163, May 1990.

BIOGRAPHIES



Nursel Akcam was born in Ardahan, Turkey, in 1964. She received the B.Sc., M.Sc. and Ph.D. degrees from Gazi University, Ankara, Turkey all in Electrical and Electronics Engineering, in 1986, 1993 and 2000, respectively. Currently, she is an Assistant Professor at Electrical and Electronics Engineering Department of Gazi University. Her research interests are in electromagnetic theory, microwave technique, antennas and radar systems



Merve Hatice Karatas was born in Corum, Turkey, in 1982. She received the B.Sc. degree from Yildiz Technical University, Istanbul, Turkey and the M.Sc. degree from Gazi University, Ankara, Turkey all in Electrical and Electronics Engineering, in 2005 and 2010, respectively. She works TSE as an Electrical and Electronics Engineering.