

SHUNT HYBRID ACTIVE POWER FILTER TO ALLEVIATE THE HARMONICS OF VSC-HVDC IN OFF-SHORE WIND FARMS

J. Khazaie D. Nazarpour M. Farsadi M. Khalilian S. Badkubi

*Electrical Engineering Department, Urmia University, Urmia, Iran
javad_khazaie@yahoo.com, d.nazarpour@urmia.ac.ir, m.farsadi@urmia.ac.ir
m.khalilian@yahoo.com, s.badkubi@yahoo.com*

Abstract- This paper studies the possible reduction of total harmonic distortion via shunt hybrid active power filter implemented in wind farms with transmission network using Voltage Source Converter based High Voltage Direct Current (VSC-HVDC) link. In general, the conversion process in the VSC-HVDC stations produces significant current harmonic problems and interfaces with other system associated. Conventionally, the passive filters were implemented to reduce such current harmonics, but they were suffering from creating resonance with other parameters of the power system. So, this paper aims to design a novel shunt hybrid active power filter on a basis of sinusoidal current control to reduce the current harmonics of the HVDC converter in wind farm generation unit. It is revealed that, hybrid active filters in these conditions provide the best achievable harmonic damping with lower rating than pure active filters and without any adverse interference with power system than passive filters. With implementation of shunt hybrid active power filter, the harmonic currents produced by the HVDC converter at the generation side are greatly attenuated. So, the source only needs to supply the fundamental component of the load. Simulation results with PSCAD/EMTDC verify the effectiveness of the proposed method.

Keywords: Shunt Hybrid Active Power Filter, VSC-HVDC, Current Harmonics, Off-Shore Wind Farm, Total Harmonic Distortion (THD).

I. INTRODUCTION

Renewable energy generation, specially wind energy, is becoming more and more common energy source in power systems with worsening of global environment and decreasing of non-renewable sources. Electrical power generated by wind farms may be supplied to local load or/and transmitted to AC grid [1].

Wind farms have variety of configurations in power systems. Some wind farms are located in sea near to the shore and can be connected to the AC grid using the conventional HVDC, the AC line or the VSC-HVDC. Compared with traditional HVDC and the AC line, in long transmission lines, the VSC-HVDC has numerous

benefits such as: flexible control of transmitted power, improving stability and power quality [2]. There are other merits which are not depicted here.

Besides of many advantages performed with VSC-HVDC link for the wind farm generation, there are some drawbacks associated with these transmission lines. In general, the conversion process in VSC-HVDC stations produces significant current harmonic problems that interfere with other system associated [3, 4]. The VSC-HVDC presents itself as nonlinear impedance to its supplying wind farm generation system and generates harmonic currents with well-known adverse effects such as: low power factor, electromagnetic interference, voltage distortion, and etc [5, 6]. These drawbacks have required researchers and power electronic engineers to propose a solution in order to minimize or alleviate these harmonics.

Passive filters have been conventionally implemented to alleviate the harmonic distortion in wind farm generation based on VSC-HVDC transmission lines. However, they have some drawbacks such as: high dependency of their performance on the system impedance, unwanted absorption of harmonic currents of nearby nonlinear loads, and risk of harmonic resonance between the passive filter and the system series impedance, which can be led to more harmonic propagation throughout the power system [6].

Active power filters, as the enhanced achievement for the harmonic problem, have achieved the drawbacks of passive filters. They inject harmonic components with appropriate magnitude and phase angle into the system, as a result, obliging harmonics of nonlinear loads from spreading into the generation unit. However, disadvantages such as: high initial cost and high power losses, limit their wide usage in power systems especially in high power applications [7].

To conquer the cited limitations imposed by passive and active filters, the hybrid power filters have been proposed and utilized in practical system applications [8]. They consist of two or more active and passive power filters in different configurations. The key characteristic of a hybrid power filter is the much smaller power rating of its power electronic converter than that of an active

power filter. This feature makes hybrid power filter as an appropriate solution for the harmonic problem in high power application where the active power filter cannot be used alone [9, 10].

This paper discusses the shunt hybrid active power filter utilized in the HVDC transmission line based on wind farm generation with focus on harmonic mitigation. The designed hybrid power filter consists of one high frequency passive filter and one low power active power filter. The proposed hybrid power filter will greatly mitigate the harmonics of VSC associated with HVDC system with low power rating and high quality of alleviation. In order to verify the superior performance this hybrid filter than the pure active power filter, a comparison is also conducted between two cited approaches.

The paper is organized as follows: section II describes the clarification of basic network model, consists of: Wind turbine model, HVDC model and its controllers. Shunt active power filter modeling and its control method on a basis of p-q theory are described in section III. Section IV covers the time domain simulation results in order to verify the information yielded in section III. Finally the conclusions are given in section V.

II. CONFIGURATION OF OFFSHORE WIND FARM VSC-HVDC SYSTEM

The main components of the VSC-HVDC transmission system used in off-shore wind farm consists of: wind turbine based fixed speed induction generator (FSIG), wind farm controller, VSC at the wind farm side and its controller, a DC cable, and VSC at the grid side with its conventional control. The combination of the power system under study is exhibited in Figure 1.

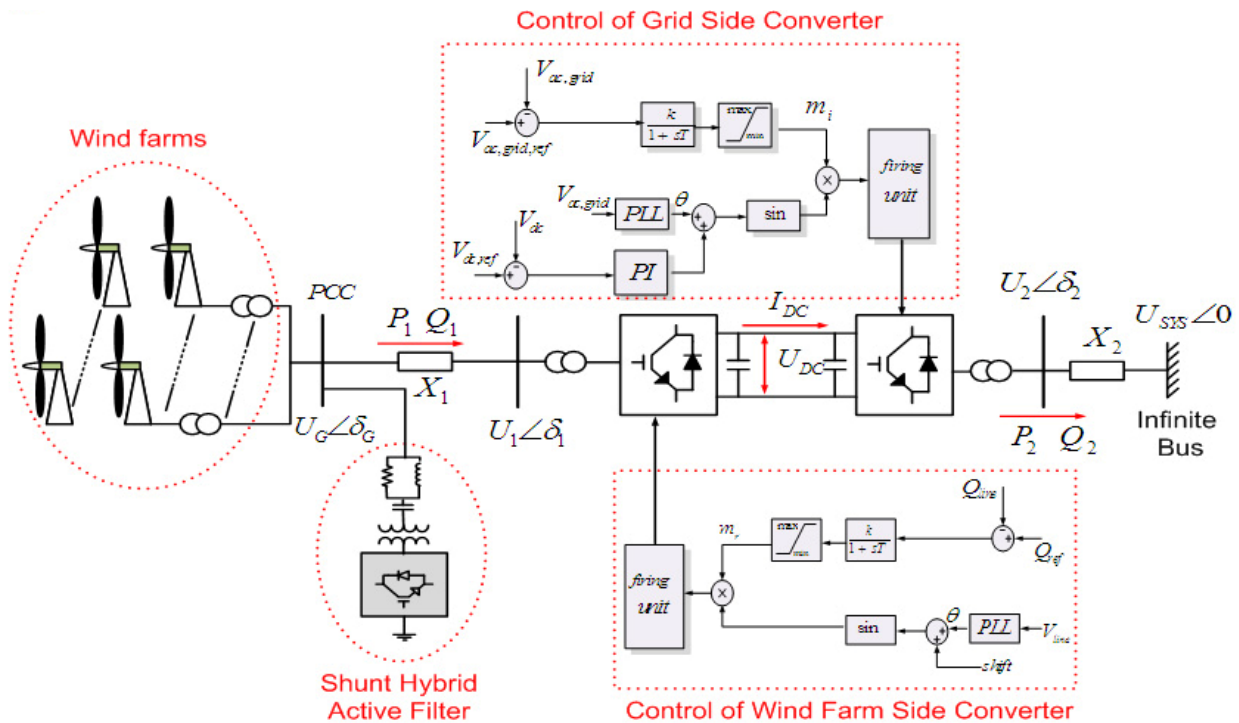

Figure 1. Wind farm generation integrated with HVDC transmission line and shunt hybrid active filter

In this paper, a 40 MW wind farm is considered which consists of 20 individual wind farms. Each wind farm resembles the commercially available 2 MW, 13.8 kV unit based on Fixed Speed Induction Generators (FSIG). Hybrid active power filter is shunt connected at the Point of Common Coupling (PCC) which will be precisely clarified at the following sections. The generation side of each wind turbine is connected to step up transformer with turn ratio of 0.575/13.8 kV. All these 20 wind turbines are connected to the same connection point on the offshore side (PCC), the sending end station. In order to transmit the generated power to on-shore side by HVDC link, a step up transformer with turn ration of 13.8/64 kV is utilized. The main objective of this investigation is to mitigate the harmonic via shunt hybrid active power filter, so a brief introduction of wind farm

and VSC-HVDC is explained in the following and the detailed information are neglected. The power system parameters are included in the appendix.

A. Wind Turbine System Modeling

Although there are many types of wind turbines, either synchronous or asynchronous, the scope of this investigation is limited to asynchronous wind turbines that are presently and widely used in wind turbines due to their low cost and convenient maintenance. Generally, a complete wind turbine model consists of an aerodynamic model, mechanical drive model, and induction generator model. The aerodynamic rotor extracts the kinetic power from the wind and exchanges this power into mechanical power. The relation between the wind speed and mechanical power is given by Equation (1) [11]:

$$P_w = \frac{1}{2} \rho \pi R^2 V_w^3 C_p(\theta, \delta) \quad (1)$$

where, P_w is the power extracted from wind (W), ρ is the air density (kg/m^3), R is the radius of the rotor of wind turbine (m), V_w is the wind speed (m/s), θ is the pitch angle of the rotor (deg), $\lambda = \frac{W_{rot} R}{V_w}$ the tip speed ratio,

where, W_{rot} is the rotor speed of wind turbine (rad/sec), C_p is the aerodynamic efficiency of the rotor which can be expressed as a function of the tip speed ratio (λ) and the pitch angle (θ) by the following equation [11]:

$$C_p = 0.22 \left(\frac{116}{\beta} - 0.4\theta - 5 \right) e^{-\frac{12.5}{\beta}} \quad (2)$$

and also, β can be expressed by:

$$\beta = \frac{1}{\frac{1}{\lambda + 0.08\theta} - 0.035 \theta^3 + 1} \quad (3)$$

Produced mechanical power is transferred into the electrical energy by generator and is fed into the grid.

B. VSC-HVDC Modeling

With arrival of high switching frequency transistors, implementation of the advanced Pulse Width Modulation (PWM) technique is enabled in the power electronic apparatuses. Furthermore, PWM technique gives the possibility of separate control of active and reactive power, which enables this technique very good for power transmission in the network [12, 13]. With implementation of the VSC for HVDC transmission system on a basis of PWM technique, the active power can be transmitted in both directions. Also, the reactive power can be generated or absorbed by VSC-HVDC system.

In this investigation, the active power generated by the wind farm is transmitted through HVDC system. On the other hand, generally, offshore wind farms have to be supplied with the reactive power, so, the VSC-based HVDC connection can be used to supply the induction generators with reactive power extracted from the power system. In order to clarify the power distribution of VSC-HVDC system, reconsider Figure 1, the main equations for active and reactive power of VSC-HVDC are revealed in the following:

$$P_1 = \frac{U_G U_1}{X_1} \sin(\delta_G, \delta_1) \quad (4)$$

$$Q_1 = -\frac{U_1^2}{X_2} + \frac{U_G U_1}{X_1} \cos(\delta_G - \delta_1) \quad (5)$$

$$P_2 = \frac{U_{sys} U_2}{X_2} \sin(\delta_2 - 0) \quad (6)$$

$$Q_2 = \frac{U_2^2}{X_2} + \frac{U_2 U_{sys}}{X_2} \cos(\delta_2 - 0) \quad (7)$$

As explained in Equations (4)-(7), the active power is controlled with phase angle control of AC side voltage of

sending end converters (wind farm side). In addition, the reactive power generated by sending-end converter is controlled by magnitude of the AC voltage on the AC side of the converter. The receiving end converter is aimed to control the DC link voltage and the AC side voltage of receiving end converter (grid side converter). The DC link voltage is controlled by adjusting the phase angle of the AC side voltage of receiving end converter. Furthermore, the magnitude of the voltage at the AC side of the receiving end converter is modified in order to control the AC voltage magnitude at the receiving end AC bus.

C. Control of Wind Farm Side Converter

The main scope of the wind farm side converter in this investigation is to control the reactive power generated or absorbed by the VSC. This reactive power is controlled by the magnitude of the converter AC voltage, which in PWM conversion is determined by modulation index. The simplified control block diagram of the wind farm side converter is also included in Figure 1. Shift signal is the phase angle order in degrees derived from open loop power controller. It is the angle by which the voltage across the sending end transformer is phase shifted in order to control the power flow. The firing unit uses the PWM reference signals at fundamental frequency. The magnitude of the reference signal is controlled by the signal m_r and its phase is controlled by the signal shift. Firing pulses are generated with comparison between reference signals and triangular signals [14].

D. Control of Grid Side Converter

The main schematic of this controller is revealed in Fig.1 too. This control aims to adjust the phase angle of receiving end converter at the AC side. Also, when the DC link voltage is higher than normal condition, the phase angle is adjusted to push power into the receiving end AC system. If the DC link voltage tends to be lower than reference value, the angle is altered in a way to receive the power from receiving end AC system in order to charge the DC link. The m_i is the modulation index of the output of controller in order to control the voltage magnitude of the grid side converter. The firing unit acts as similar as cited in wind farm side converter controller [14].

III. SHUNT HYBRID ACTIVE POWER FILTER MODELING

In recent years, harmonic currents are serious problems for the power system due to increasing application of non-linear loads, such as: diode or thyristor converters. In this paper, VSC-HVDC system acts as a non-linear load, creates a current harmonic which is highly distorted and wind farm acts as a source, produces power. Active power filters enable strong validity in eliminating harmonics which can conquer the main drawbacks of the passive filters which was cited above, but these active filters suffer from high initial costs and ratings.

The shunt hybrid power filters are very popular in industrial applications because of their numerous benefits. In this combination, active power filter suppresses mainly the low order harmonics rather than high order harmonics and the passive power filter aims to suppress the high order frequencies or some special low orders. Consequently, the combined system can solve the problems inherent in using only active filters or only passive filters. Furthermore, proposed hybrid active power filter is much smaller in rating than traditional active power filters.

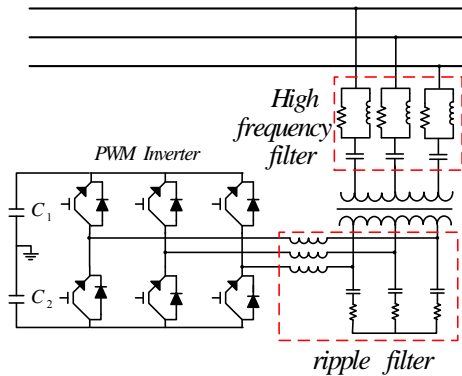

Figure 2. Main configuration of proposed hybrid active power filter

Figure 2 shows the circuit configuration of the shunt hybrid power filter which consists of: a single-tuned passive filter in series with the active power filter (the passive power filter is tuned for high-order frequencies), the active filter which is a voltage source inverter with IGBT switches, and a DC capacitor for providing DC voltage. A coupling transformer is implemented for connecting the passive filter in series with active filter. Furthermore, a low pass filter is granted to the active power filter in order to mitigate the inverter output voltage ripples due to the high frequency switching. The filter parameters are included in Table 1. The active power filter parameters are included in Table 2. In the following, the hybrid active power filter on a basis of sinusoidal current control is investigated.

A. Active Filter for Sinusoidal Current Control

Harmonic and reactive power compensation are two methods that make the active filters compensate the current of a nonlinear load to force the compensated source current to become sinusoidal and balanced. A systematic mathematical formulation of p-q theory is given below [15]:

In a three-phase system, the instantaneous voltages and currents can be expressed as space vector in a-b-c plane. The load current vectors ($\vec{i}_{La}, \vec{i}_{Lb}, \vec{i}_{Lc}$) can be transformed in coordinate [p-q theory] as follows:

$$\begin{bmatrix} V_\alpha \\ V_\beta \end{bmatrix} = \sqrt{\frac{2}{3}} \begin{bmatrix} 1 & -1 & -1 \\ 0 & \frac{\sqrt{3}}{2} & \frac{-\sqrt{3}}{2} \end{bmatrix} \begin{bmatrix} V_a \\ V_b \\ V_c \end{bmatrix} \tag{8}$$

$$\begin{bmatrix} i_{L\alpha} \\ i_{L\beta} \end{bmatrix} = \sqrt{\frac{2}{3}} \begin{bmatrix} 1 & -1 & -1 \\ 0 & \frac{\sqrt{3}}{2} & \frac{-\sqrt{3}}{2} \end{bmatrix} \begin{bmatrix} i_{La} \\ i_{Lb} \\ i_{Lc} \end{bmatrix} = [C] \begin{bmatrix} i_{La} \\ i_{Lb} \\ i_{Lc} \end{bmatrix} \tag{9}$$

where, [C] is called the Clarke Transformation matrix, α and β are the axes of an orthogonal plane with the α -axis being synchronized with the a-axis of a-b-c plane and the β -axis being orthogonal to the α -axis. The instantaneous real power of a three phase load can be defined as:

$$P = V_\alpha \cdot i_\alpha + V_\beta \cdot i_\beta = V_a \cdot i_a + V_b \cdot i_b + V_c \cdot i_c \tag{10}$$

The instantaneous imaginary power q of the three phase load is defined as:

$$q = V_\alpha \cdot i_\beta - V_\beta \cdot i_\alpha \tag{11}$$

The instantaneous real power (p) and reactive power (q) of the load can be further divided in to DC and AC components as given below:

$$p = \tilde{p} + \bar{p}, q = \tilde{q} + \bar{q} \tag{12}$$

where, \bar{p}, \bar{q} are the DC components of the real and reactive power and \tilde{p}, \tilde{q} are the AC components of the real and reactive power respectively.

Note that, the system voltages may be distorted by the harmonic currents as well as the ripple generated by the active filter. So, the current calculated with the previous equation will not exactly compensate the harmonic. So, a Fundamental Positive Sequence Voltage Detector (FPSVD) is used to determine the amplitude of the positive sequence voltage and the output of this block is pure sinusoidal phase voltages (V_a, V_b, V_c) which are used to synchronize the filter currents and also to calculate the instantaneous powers.

If the shunt active filter compensates the power \tilde{p} and \tilde{q} of the calculated powers p and q, it is compensating all components in the load current also fundamental negative-sequence component. For this goal, the current references of active filter should be calculated for current control loop. The relationship between \tilde{p}, \tilde{q} and active filter reference currents ($i_{c\alpha}^*, i_{c\beta}^*$) is:

$$\begin{bmatrix} i_{c\alpha}^* \\ i_{c\beta}^* \end{bmatrix} = \frac{1}{V'_\alpha + V'_\beta} \begin{bmatrix} V_\alpha & V_\beta \\ V_\beta & -V_\alpha \end{bmatrix} \begin{bmatrix} -\tilde{p} + \bar{p}_{loss} \\ -q \end{bmatrix} \tag{13}$$

A block diagram of the active filter for sinusoidal current control is shown in Figure 3 [15]. The DC voltage control loop compares the measured DC link voltage with its reference value and the attained error is then sent to a PI controller. The output of the PI controller namely p_{loss} , is the power that should be absorbed by the converter to maintain the DC voltage level. Sum of this power with the AC component of the real power is then implemented to calculate the reference current values for proposed shunt active filter. Furthermore, the q is transmitted to current calculation block to yield the reference current value too [15].

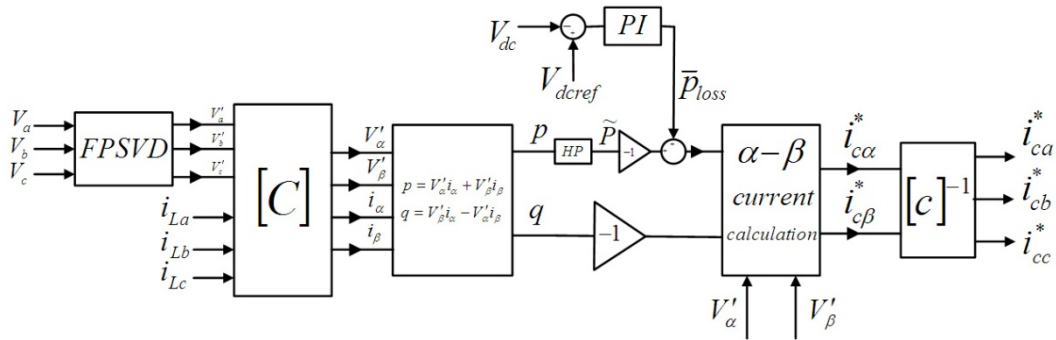

Figure 3. Power control blocks of the hybrid active filter

In the current control loop, the sampled inverter phase currents (I_{Fa}, I_{Fb}, I_{Fc}) are compared, one by one, to the reference currents ($i_{ca}^*, i_{cb}^*, i_{cc}^*$) with three hysteresis compensators, determining the firing signals of the inverter. The inverter currents are samples at fixed frequency, in order to update with the comparator just at sampling instants. Also, the maximum commutation frequency of the inverter is restricted to frequency around the sampling frequency. He Hysteresis-based current control is a common Pulse Width Modulation (PWM) control (which is widely used in voltage-source converters) to oblige these converters to behave as a controlled AC current source to the power system [15]. It should be noted that, $i_k^* (k = a, b, c)$ are the instantaneous current references provided by an active filter controller.

IV. SIMULATION RESULTS

In order to verify the performance of proposed shunt hybrid power filter in mitigating the harmonics associated with HVDC-Based wind farm generation, appropriate simulations of power system are performed. It is obvious that, the reactive power control can be independently applied in case of VSC-based HVDC without any impact on other system constants. The possibility of independent control of reactive power by VSC-based HVDC is not included in simulations. Furthermore, the main aim of HVDC transmission line is to transmit the power generated by wind farm into the grid.

In this part, in order to compare the results of proposed shunt hybrid active power filter with pure shunt active power filter, first, a pure active power filter is implemented for harmonic mitigations. Fig.4 demonstrates the simulation results when just active power filter is shunt connected to the power system and there is no passive power filter in system. Shunt active power filter operates at time 5 sec and its duty is to alleviate the harmonic currents of VSC-HVDC transmission system. Figure 4 (a)-(c) demonstrates the VSC-HVDC current, the wind farm side current, and the current which is produced by the shunt active power respectively. From Figure 4, it can be obtained that, the load current (VSC-HVDC) contains notable harmonic currents and this harmonic currents distort the source current (wind farm side current), but after operation of shunt active power filter, harmonic currents of the load can be well attenuated and the compensating currents can

track the harmonic currents effectively. As it is observed in Figure 4 (a), the utility currents are nearly sinusoidal after operation of active power filter. This verifies that, the proposed three-phase active power filter can suppress the harmonic currents. Figure 4 (c) exhibits the current generated by active power filter in order to compensate the harmonic currents of the load. The shunt active power filter proposed here can perform the harmonic attenuation without any passive filters, but if small passive filter is granted to this active power filter, the power rating of active power filter will be greatly declined.

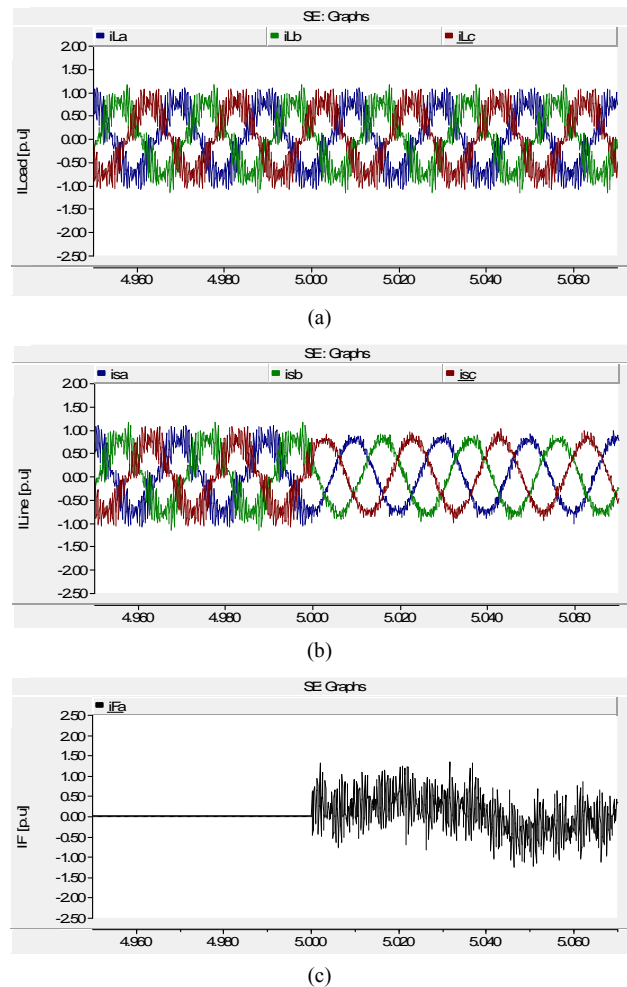

Figure 4. Simulation results for current at the different sides of the power system after operation of active filter: (a) the VSC (load) currents , (b) the wind farm (source) currents , (c) the active power filters current at phase a

Now, consider a condition in which proposed hybrid active power filter operates at the PCC of the power system in order to alleviate the adverse harmonics. In this condition, the high order harmonics which were not eliminated by pure active power filter, are well attenuated by implementation of high-order passive filter. Figure 5 (a)-(c) depicts the VSC-HVDC current, wind farm side current, and hybrid power filter generated currents respectively when the hybrid active power filter operates. Figure 5 (b) reveals that, the wind farm side current is purely sinusoidal when the hybrid power filter operates. This is the best achievable damping performance with combination of active and passive power filters. In comparison between hybrid and active power filter, the hybrid power filter has superior performance in damping of harmonics than its counterpart, pure active power filter.

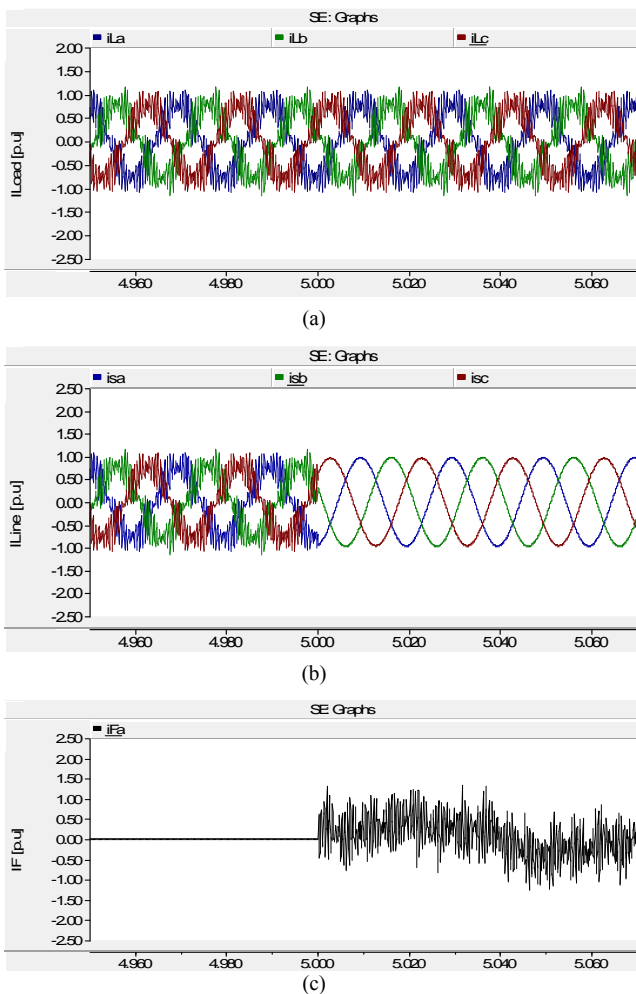

Figure 5. Simulation results for current at the different sides of the power system after operation of Hybrid active power filter: (a) the VSC (load) currents , (b) the wind farm (source) currents , (c) the active power filters current at phase a

Figure 6 (a) shows the spectrum of wind farm side (source) current which was earlier depicted in Figure 4 (a) before operation of active power filter. It demonstrates the first 63 order harmonics of this current. It is observed from Figure 6 (a) that, the source current contains great value of high harmonic orders (31, 35, 63, and 61)

besides of its low order harmonics such as: 5, 7, 11, and 13. Furthermore, it should be noted that, the amplitude of the high order harmonics is much greater than low order ones, so as earlier was depicted in Figure 4 (c), the active filter is more likely to compensate the high order harmonics than low orders, or in other expression, it is the reason why the active filter current contains high frequency orders. Figure 6 (b) demonstrates the first 63 order harmonics of this current after operation of pure shunt active power filter. It is great of interest that, the Total Harmonic Distortion (THD) is decreased from 37% to 7% after active power filter operation. Furthermore, there is no passive filter supplemented to an active filter and the harmonic attenuation is achieved only with active power filter. It is observed from Figure 6 (b) that, the active filter not only compensates the high order harmonics, but also it decreases the lower harmonic orders, but the current still contains high order harmonics and is not purely sinusoidal. After operation of hybrid active power filter the spectrum of harmonics become nearly zero which is not included in figures. Total harmonic distortions of each part are included in Table 3.

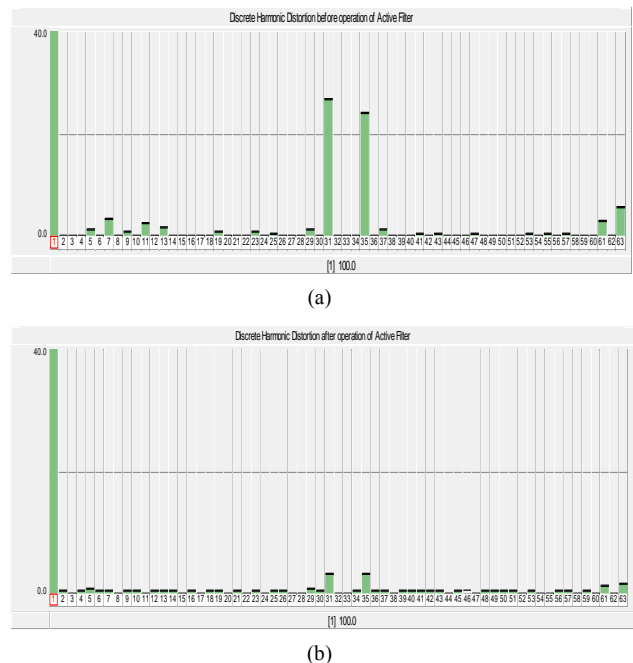

Figure 6. (a) Discrete harmonic distortion of each harmonic order without operation of active filter , (b) Discrete harmonic distortion of each harmonic order after operation of pure active filter

Figure 7 demonstrates the generated active power of wind farms. The power generated by wind farms is purely constant before operation of hybrid active filter at time 5 sec. when hybrid active filter performs; the generated power faces with small oscillations which completely are damped after few seconds. It should be noted that, the wind turbine begins to operate at time 2 sec and before that, the system operates with constant voltage sources. It should be noted that the parameters of the power system are included in Table 4.

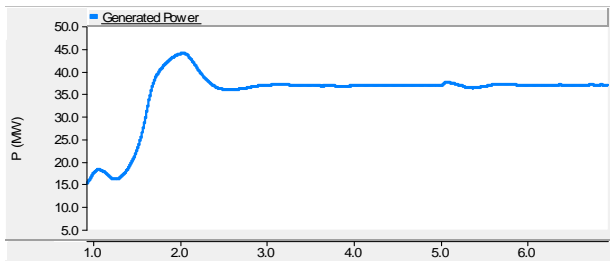

Figure 7. The active power generated by wind farm

V. CONCLUSIONS

This paper dealt with a hybrid shunt active power filter for installation on a wind farm generation unit based on VSC-HVDC transmission system. Furthermore, the main scope of this work is on total harmonic distortion reduction. The solution will be more beneficial than conventional passive filters which have adverse resonance effect on the power system. Also, hybrid power filters provide significantly lower rating than pure active power filters. Simulation results verify that, implemented pure shunt active power filter can also attenuate the harmonic currents associated with VSC-HVDC transmission system. Furthermore, the best achievable damping performance is acquired when the hybrid active power filter performs. It is also concluded that, operation of hybrid power filter not only improves the power system condition, but also increases the power quality of generation system.

APPENDICES

Table 1. Passive filters parameters

High pass filter		Ripple filter	
C_h	11.5 μ F	c	0.1 μ F
L_h	7.3 mH	L	1 mH
R_h	0.3 Ω	R	0.02 Ω

Table 2. Active filter parameters

Active Power Filter Parameters	
C_1, C_2	2000 μ F
V_{DCref}	3 KV
Switching frequency	12 KHz
Fundamental frequency	50 Hz
Hysteresis band	0.002
Base power	26 MVA
Base voltage	13.8 KV
Transformer turn ratio	13.8/6.75
Transformer windings	YD

Table 3. Total harmonic distortion

Percentage of THD	
No filter	37%
Active filter	7%
Hybrid filter	2%

Table 4. Wind turbines and HVDC parameters

Fixed Speed Induction Generators	
Base voltage	4 KV
Base power	2MVA
Frequency	50 Hz

Base speed	314 rad/s
Stator resistance	0.066 p.u
Magnetizing resistance	3.86 p.u
Magnetizing inductance	0.105 p.u
Leakage inductance	0.046 p.u
Wind Turbines	
Rotor radius	60 m
Rotor area	11304 m ²
Air density	229 kg/m ³
Gearbox efficiency	0.97 μ F
Wind speed	10 m/s
HVDC System	
DC cable	100 Km
R_{dc}	5 Ω
Number of conductors	2
C_1, C_2 (capacitors of sending end VSC)	250 μ F
C_3, C_4 (capacitors of receiving end VSC)	220 μ F
Switching frequency	3 KHz
Fundamental frequency	50 Hz

REFERENCES

[1] European Wind Energy Association, Wind Energy-The Facts, 2004, <http://www.ewea.org> .

[2] B.T. Ooi, X. Wang, "Voltage Angle Lock Loop Control of the Boost Type PWM Converter for HVDC Application", IEEE Transactions on Power Electronics, Vol. 5, No. 2, pp. 229-235, April 1990.

[3] E. Spahic, G. Balzer, "Impact of the VSC HVDC Connection of Large Offshore Wind Farms on Power System Stability and Control", IEEE Power Tech, pp. 207-212, Lausanne, 2007.

[4] A. Nayir, E. Rosolowski, L. Jedut, "New Trends in Wind Energy Modeling and Wind Turbine Control", International Journal on Technical and Physical Problems of Engineering (IJTPE), Issue 4, Vol. 2, No. 3, pp. 51-59, September 2010.

[5] M. Hajibeigi, M. Farsadi, Kh. Behboudi Asl, "A Modified Structure of Hybrid Active DC Filter in HVDC System", International Journal on Technical and Physical Problems of Engineering (IJTPE), Issue 10, Vol. 4, No. 1, pp. 11-16, March 2012.

[6] J.S. Subjak Jr., J.S. Mcquilkiln, "Harmonic Causes, Effects, Measurements, Analysis: An Update", IEEE Transaction on Industry Applications, Vol. 26, pp. 1034-1042, 1990.

[7] H.L. Jou, J.C. Wu, Y.J. Chang, Y.T. Feng, "A Novel Active Power Filter for Harmonic Suppression", IEEE Transactions on Power Delivery, Vol. 20, No. 2, pp. 1507-1513, April 2005.

[8] H. Fujita, H. Akagi, "A Practical Approach to Harmonic Compensation in Power Systems - Series Connection of Passive and Active Filters", IEEE Transactions on Industry Applications, Vol. 27, No. 6, pp. 1107-1112, November/December 1991.

[9] F.Z. Peng, H. Akagi, A. Nabae, "A Novel Harmonic Power Filter", Conf. Rec. IEEE PESC'88, Vol. 2, pp. 1151-1159, April 1988.

[10] H. Fujita, H. Akagi, "A New Approach to Harmonic Compensation in Power Systems - A Combined System of Shunt Passive and Series Active Filters", IEEE

Transactions on Industry Applications, Vol. 26, No. 6, pp. 983-990, 1990.

[11] S. Heier, "Grid Integration of Wind Energy Conversion System", Wiley, Chichester, UK, 1998.

[12] C. Hairong, X. Zheng, "Transient Model and Controller Design for VSC-HVDC Based on Synchronous Reference Frame", Transaction of China Electro Technical Society, Vol. 22, No. 2, pp. 121-126, February 2007.

[13] Y. Gangui, C. Tao, M. Gang, L. Wenhua, "Dynamic Modeling and Nonlinear-Decouple Control of HVDC Light System", Power System Technology, Vol. 31, No. 6, pp. 45-50, March 2007.

[14] "HVDC Light Topology", ABB Handbook, 1999.

[15] H. Akagi, E. Watanabe, M. Aredes, "Instantaneous Power Theory and Applications to Power Conditioning, Ser. Power Engineering", IEEE Press, Piscataway, NJ, 2007.

BIOGRAPHIES



Javad Khazaie was born in Ghaemshahr, Iran, 1987. He received the B.Sc. degree from University of Nooshirvani, Babol, Iran. Currently, he is studying his M.Sc. in Electrical Engineering in Urmia University, Urmia, Iran. His research interests are in the areas of FACTS, power quality,

and active power filters. He is a member of the International Electrical and Electronic Engineers.



Daryoosh Nazarpour received the B.Sc. degree from Iran University of Science and Technology in 1982 and the M.Sc. and Ph.D. degrees in Electric Power Engineering from Tabriz University, Tabriz, Iran in 1988 and 2005, respectively. He is now an Assistant Professor in Urmia University,

Urmia, Iran. His research interest areas are advanced power electronic and FACTS.



Murtaza Farsadi received B.Sc. degree from Electrical Engineering, Middle East Technical University, Ankara, Turkey in 1982 and M.Sc. degree in Electrical and Electronics Engineering from the same university in 1984, and received Ph.D. in Electrical Engineering

(High Voltage), Department of Electrical & Electronics Engineering, Middle East Technical University (Ankara, Turkey) and Istanbul Technical University (Istanbul, Turkey) in 1989. He is now an Assistant Professor in Urmia University, Urmia, Iran. His research interests are high voltage DC defibrillator, hybrid and electrical vehicle, wind energy, new methods of electrical machine control, biomedical engineering apparatus, electrical treeing.



Mansour Khalilian was born in Isfahan, Iran. He received the B.Sc. degree from Najafabad Branch, Islamic Azad University, Isfahan, Iran. Currently, he is studying his M.Sc. in Electrical Engineering in Urmia University, Urmia, Iran. His research interests are in the area of advanced

power electronics, power quality, and FACTS.



Salman Badkubi was born in Isfahan, Iran, 1984. He received the B.Sc. degree from Isfahan University of Technology, Isfahan, Iran. Currently, he is studying his M.Sc. in Electrical Engineering in Urmia University, Urmia, Iran. His research interest is in the area of FACTS.